

testo 845 – the infrared measurement technology for temperature with integrated humidity module

The testo 845 is a milestone in non-contact temperature measurement. For the first time, surface temperatures with smallest diameters can be measured accurately at short and long distances. The switchable optics for far-field and close focus measurement make this possible.

testo 845 is equipped with an optical resolution of 75:1 for far-field measurements. Surface temperatures can be measured accurately even at great distances from the object to be measured. At a distance of 1.2 metres from the object to be measured, the measuring spot diameter is only 16 mm. A cross laser marks the measuring spot exactly during measurement. Incorrect measurements are eliminated - you always know exactly where you are measuring.

The close focus optics allow the measurement of temperatures on the smallest surfaces with a diameter of just 1 mm and a distance of 70 mm! Two lasers mark the measuring spot exactly.

- Switchable optics for far-field measurements (75:1) and close focus (1 mm, 70 mm distance)
- Especially bright cross laser sighting for indicating the actual measuring point
- Reference accuracy ± 0.75 °C with super-fast measurement technology (scanning 100 ms)
- Backlit display (3-line), shows °C, min./max. values, alarm limit values and emissivity; in addition display with humidity module: %RH, °Ctd
- Optical and audible alarm when limit values are exceeded
- Instrument memory for 90 measurement protocols
- PC software for archiving and documenting measurement data (included in delivery)
- Tripod fitting for online measurement via USB cable (included in delivery)



Switch optics 1:
Far-field 75:1 (16 mm,
distance 1200 mm) with
cross laser marking



Switch optics 2:
close focus (1 mm,
distance 70 mm) with 2-
point laser marking



testo 845 with additional
humidity module for
measuring ambient air
humidity and for
determining
dewpoint
distance



Fast documentation with
measurement data
printout on site



Infrared Thermometer with Switchable Optics (far-field/close focus)

testo 845



testo 845, infrared temperature measuring instrument with cross-laser sighting, switchable optics for far-field and close focus measurement, contact temperature probe attachable, optical/audible alarm, reading memory, PC software incl. USB data transfer cable, aluminium case, battery and calibration protocol

Part no. 0563 8450

testo 845 with integrated humidity module

testo 845, infrared temperature measuring instrument with cross laser sighting incl. humidity module, switchable optics for far-field and close focus measurement, contact temperature probe attachable, optical/audible alarm, reading memory, PC software incl. USB data transfer cable, aluminium case, battery and calibration protocol

Part no. 0563 8451

Description	Meas. range	Part no.
Fast-action surface probe with sprung thermocouple strip, also for uneven surfaces, measurement range short-term to +500°C, TC Type K	-60 to +300 °C	0602 0393
		
Robust air probe, T/C Type K	-60 to +400 °C	0602 1793
		

Accessories Ordering data	Part no.
Humidity module, upgradeable for testo 845 (0563 8450)	0636 9784
Plug-in mains adapter, 5 VDC 500 mA with European adapter, 100-250 VAC, 50-60 Hz	0554 0447
External fast charger for 1-4 AA rech. batteries, incl. 4 Ni-MH rech. batteries with individual cell charging and charge control display, incl. impulse trickle charging, integrated discharge function, with built-in international mains plug, 100-240 V, 300 mA, 50/60 Hz	0554 0610
Testo fast printer with wireless infrared interface, 1 roll thermal paper and 4 AA batteries, for printing out measurements on site	0554 0549
Spare thermal paper for printer (6 rolls), measurement data documentation legible for up to 10 years	0554 0568
testo saline pots for control and humidity adjustment of humidity probes, 11.3 %RH and 75.3 %RH with adapter for humidity probe	0554 0660
Adhesive tape, e.g. for bare surfaces (roll, L.: 10 m, W.: 25 mm), E = 0.95, temperature resistant to +250 °C	0554 0051
Silicone heat paste (14g), T _{max} = +260°C, improves heat transfer in surface probes	0554 0004
ISO calibration certificate/temperature, infrared thermometer; calibration points +60°C; +120°C; +180°C	0520 0002
ISO calibration certificate/temperature, infrared thermometers; calibration points -18°C, 0°C, +60°C	0520 0401

Far-field measurement

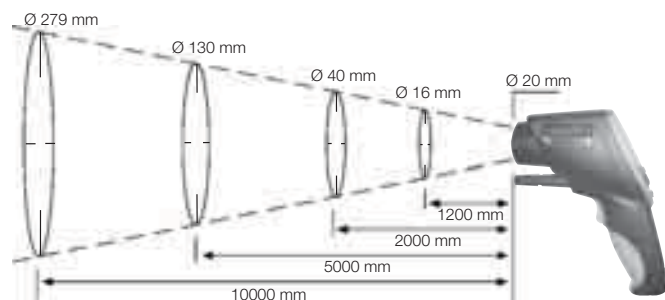

Probe socket for TC probes for determining emissivity

Aluminium case for instrument and accessories (included)

Monitoring the exact temperature during the production process

Technical data	Infrared	Contact (type K)	Humidity module
Meas. range	-35 to +950 °C	-35 to +950 °C	0 to +100 %RH 0 to +50 °C -20 to +50 °C td
Accuracy ±1 digit	±2.5 °C (-35 to -20.1 °C) ±1.5 °C (-20 to +19.9 °C) ±0.75 °C (+20 to +99.9 °C) ±0.75% of mv (+100 to +950 °C)	±0.75 °C (-35 to +75 °C) ±1% of mv (+75.1 to +950 °C)	±2 %RH (2 to 98 %RH) ±0.5 °C (+10 to +40 °C) ±1 °C (remaining range)
Resolution	0.1 °C	0.1 °C	0.1 °C td
Emission factor	Adjustable 0.1 to 1.0		
Optical resolution	Far-field: (75:1) 16 mm, 1200 mm distance (90%) Close focus: 1 mm, 70 mm distance (90%)		
Measuring rate	t ₉₅ : 250 ms; Scanning Max/Min/Alarm: 100 ms		
Dimensions	155 x 58 x 195 mm		
Battery type	2 AA batteries		
Battery life	25 h (without laser), 10 h (with laser without light), 5 h (with laser and 50% light)		
Material/Housing	ABS Black/gray, metal screen		
Oper. temp.	-20 to +50 °C		
Storage temp.	-40 to +70 °C		

Close focus measurement

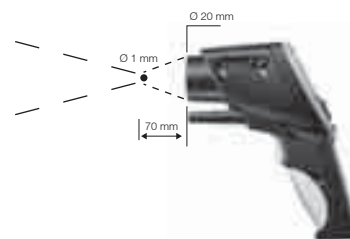

Switch to far-field measurement at a measurement distance > 250 mm.

